

MASTER DRAWING LIST

This drawing and specifications, herein, are the property of Digital Equipment Corporation and shall not be reproduced or copied or used in whole or in part as the basis for the manufacture or sale of items without written permission.

DWG. NO.	REV. LET.	NO OF SHEETS	TITLE
C-UA-DW08-0-0		1	BUS CONVERSION
A-PL-DW08-0-0		1	BUS CONVERSION
C-DI-DW08-0-1	A	1	DRAWING INDEX LIST
D-MU-DW08-B-MU	A	1	MODULE UTILIZATION
A-PL-DW08-B-MU	A	1	MODULE UTILIZATION
D-BS-DW08-B-NC1		1	NEGATIVE CONVERSION 1
D-BS-DW08-B-NC2		1	NEGATIVE CONVERSION 2
D-BS-DW08-B-PC1	A	1	POSITIVE CONVERSION 1
D-BS-DW08-B-PC2	A	1	POSITIVE CONVERSION 2
D-IC-DW08-B-NBI		1	NEGATIVE BUS IN & OUT
D-IC-DW08-B-PS	A	1	POSITIVE BUS IN & OUT
C-AD-7005934-0-0		1	WIRED ASSY DW08-B
A-PL-7005934-0-0		1	WIRED ASSY DW08-B (PL)
K-WL-DW08-B-WL	B	1	WIRE LIST DW08-B
A-AL-DW08-B-3		1	NEGATIVE TO POSITIVE CONVERTER I/O
A-SP-DW08-B-2		5	NEGATIVE TO POSITIVE BUS CONVERTER
A-SP-KA81-0-3	///	8	PROGRAM DESCRIPTION
A-SP-KA81-0-4	///	5	I/O LEVEL CONVERTER BUS CHECKOUT-PROCEDURE

REVISIONS				DRN R. HUTNAK	DATE 8/2/68	<div style="display: flex; align-items: center;"> DIGITAL EQUIPMENT CORPORATION <small>MAYNARD, MASSACHUSETTS</small> </div>			
REV	DATE	CHG. NO.	APP'D.	CHK'D	DATE				
A	3/11/69	00001	M.E.A.	A. PEYFFER	10/12/68	TITLE BUS CONVERSION (NEGATIVE)			
B	5/69	KA81-55	M.E.A.	ENG	DATE				
C	2/70	00002	M.A.	PROJ. ENG.	DATE				
D	4/70	MISC.64	M.A.	PROD.	DATE				
				FIRST USED ON					
				SCALE	NONE	SIZE	CODE	NUMBER	REV.
				SHEET	1	OF	1	DW08-B	D
				DIST					

This drawing and specifications, herein, are the property of Digital Equipment Corporation and shall not be reproduced or copied or used in whole or in part as the basis for the manufacture or sale of items without written permission.

NOTES:

1. REFER TO DRAWING INDEX NO. C-DI-DW08-0-1

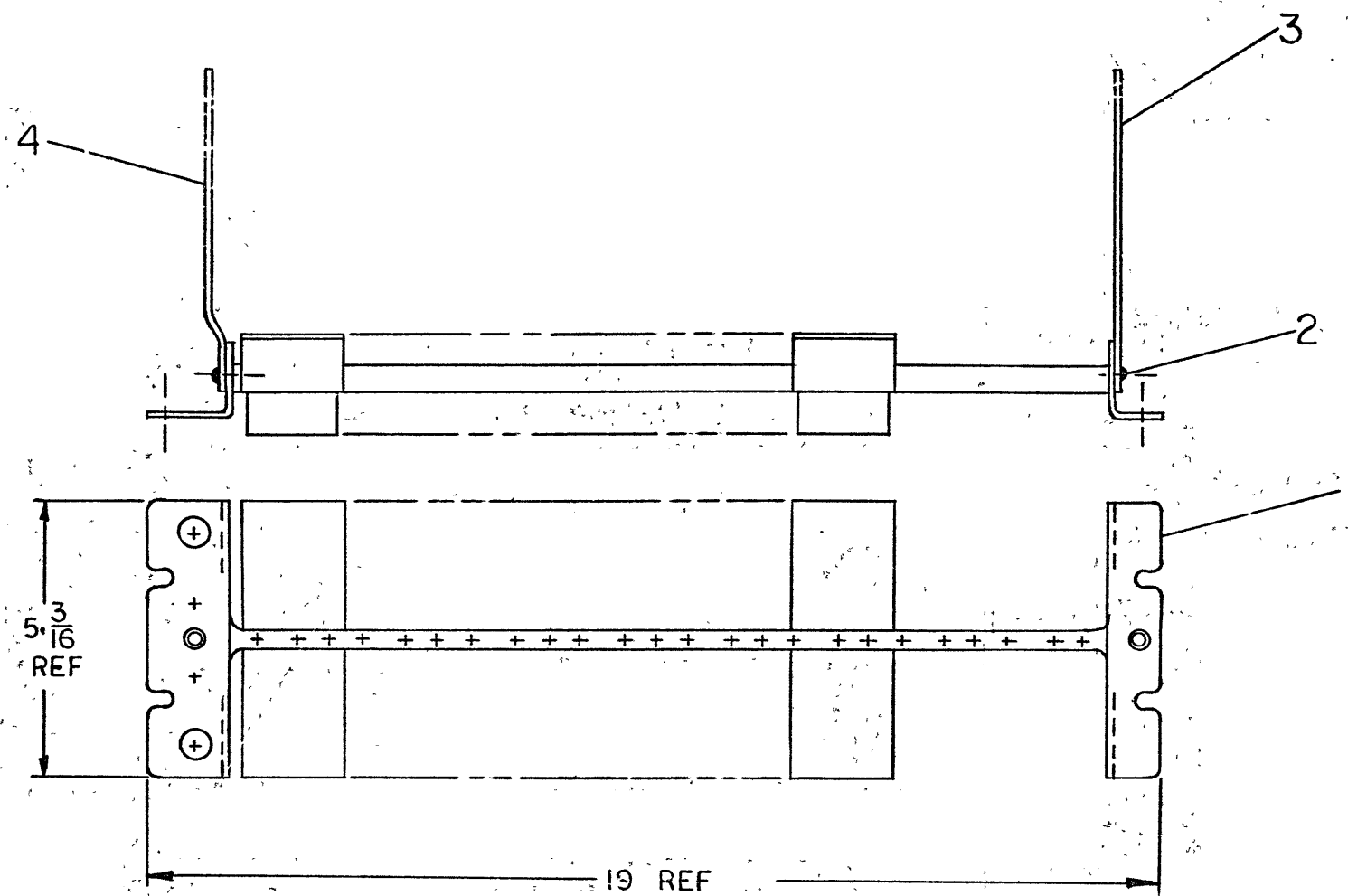

REV.	
CHG. NO.	
CHK	

FIRST USED ON OPTION/MODEL PDP-8I	QTY.	DESCRIPTION	PART NO.	ITEM NO.
PARTS LIST				
UNLESS OTHERWISE SPECIFIED	DRY	DATE	DIGITAL EQUIPMENT CORPORATION MAYNARD MASSACHUSETTS	
DIMENSION IN INCHES	1/8" & 1/16"	8/7/68	TITLE BUS CONVERSION	
TOLERANCES	CHWD	DATE		
DECIMALS FRACTIONS ANGLES	1/8" & 1/16"	10/13/68		
± .005 ± 1/64 ± 0°30'	ENG	DATE		
FINAL SURFACE QUALITY ✓ REMOVE BURRS AND BREAK SHARP CORNERS	COJ. ENG.	DATE		
MATERIAL	1/8" & 1/16"	10/13/68	SIZE CODE NUMBER REV.	
	NEXT HIGHER ASSY		CJA DW08-0-0	
FINISH	A-ML-DW08-A-0 B-0		DIST. G	
	SCALE NONE			
	SHEET 1 OF 1			

REV. NUMBER
CJA DW08-0-0

A

DIGITAL EQUIPMENT CORPORATION

MAYNARD, MASSACHUSETTS

PARTS LIST

QUANTITY/VARIATION

MADE BY	R. HUTNAK	CHECKED	AL PFFYFFER
DATE	8/8/68	DATE	8/23/68
ENG	<i>J. Chouh</i>	PROD	<i>8. J. J. J.</i>
DATE	10/11/68	DATE	10/16/68
		SECTION	1
		ISSUED SECT.	1

ITEM NO	DWG NO./PART NO.	DESCRIPTION
1	C-AD-7005933-0-0	WIRED ASSY DW08-A
1	C-AD-7005934-0-0	WIRED ASSY DW08-B
2	90-06509	RIVET, POP, AD43BS USMC
3	C-MD-5302486-0-0	PANEL, RIGHT END
4	C-MD-5302485-0-0	PANEL, LEFT END
5	D-UA-BC08A-0-0	BC08A CABLE (FLEX-PRINT)
5	D-UA-BC08B-0-0	BC08B CABLE (COAX)
5	D-UA-BC08C-0-0	BC08C CABLE (FLEX-PRINT)
5	D-UA-BC08D-0-0	BC08D CABLE (COAX)
NOTE: BC08C AND BC08D ARE FOR DIRECT INTERFACE TO PDP 8/I WITH KASI. BC08A AND BC08B ARE FOR INTERFACE PDP 8/L AND OTHER POSITIVE BUS OPTIONS.		

DW08-A	DW08-B														
1															
	1														
8	8														
1	1														
1	1														
A/RA/R															
A/RA/R															
A/RA/R															
A/RA/R															
SEE NOTE															

TITLE	ASSY NO.	SIZE CODE	NUMBER	REV.	ECO NO
BUS CONVERSION	C-UA-DW08-0-0	A PL	DW08-0-0		
SHEET 1 OF 1		DIST.			

This drawing and specifications, herein, are the property of Digital Equipment Corporation and shall not be reproduced or copied or used in whole or in part as the basis for the manufacture or sale of items without written permission.

MECHANICAL			DEPT USAGE			ELECTRICAL			DEPT USAGE		
FIND NO	DESCRIPTION	PART NO.	PROD	CUST	F/C	FIND NO	DESCRIPTION	PART NO.	PROD	CUST	F/C
1	BUS CONVERSION BUS CONVERSION (PL) PANEL, RIGHT END PANEL, LEFT END	C-UA-DW08-0-0 A-PL-DW08-0-0 C-MD-5302486-0-0 C-MD-5302485-0-0				1	BUS CONVERSION (POSITIVE) MODULE UTILIZATION MODULE UTILIZATION (PL) NEGATIVE CONVERSION 1 NEGATIVE CONVERSION 2 POSITIVE CONVERSION 1 POSITIVE CONVERSION 2 NEGATIVE BUS IN & OUT POSITIVE BUS IN & OUT WIRE LIST, DW08-A ACCESSORY LIST ACCESSORY LIST BUS CONVERSION (NEGATIVE) MODULE UTILIZATION MODULE UTILIZATION (PL) NEGATIVE CONVERSION 1 NEGATIVE CONVERSION 2 POSITIVE CONVERSION 1 POSITIVE CONVERSION 2 NEGATIVE BUS IN & OUT POSITIVE BUS IN & OUT WIRE LIST, DW08-B	A-ML-DW08-A D-MU-DW08-A-MU A-PL-DW08-A-MU D-BS-DW08-A-NC1 D-BS-DW08-A-NC2 D-BS-DW08-A-PC1 D-BS-DW08-A-PC2 D-IC-DW08-A-NB1 D-IC-DW08-A-PS K-WL-DW08-A-WL A-AL-DW08-A-3 A-AL-DW08-B-3 A-ML-DW08-B D-MU-DW08-B-MU A-PL-DW08-B-MU D-BS-DW08-B-NC1 D-BS-DW08-B-NC2 D-BS-DW08-B-PC1 D-BS-DW08-B-PC2 D-IC-DW08-B-NB1 D-IC-DW08-B-PS K-WL-DW08-B-WL			
2	WIRED ASSY, DW08-A WIRED ASSY, DW08-A (PL) WIRED ASSY, DW08-B WIRED ASSY, DW08-B (PL) LOGIC FRAME DECAIS	C-AD-7005933-0-0 A-PL-7005933-0-0 C-AD-7005934-0-0 A-PL-7005934-0-0 A-DC-7406371-0-0									
3	1943 CASTING PLUS PINS 1943 CASTING PLUS PINS (PL) 1943 FRAME CASTING	D-AD-5302483-0-0 A-PL-5302483-0-0 E-MD-1202885-0-0									

①
BUS CONVERSION
(DW08-A)
C-UA-DW08-0-0

BUS CONVERSION
(DW08-B)
C-UA-DW08-0-0

②
WIRED ASSY
(DW08-A)
C-AD-7005933-0-0

WIRED ASSY
DW08-B
C-AD-7005934-0-0

③
1943 CASTING
PLUS PINS
D-AD-5302483-0-0

REV.	CHANGE NO.	DATE
A	00064	4-7-70
CHK	FV	ARSENAL
		7-5-70

ASSY DWG NO. C-UA-DW08-0-0

UNLESS OTHERWISE SPECIFIED

UNLESS OTHERWISE SPECIFIED
DIMENSION IN INCHES
TOLERANCES
DECIMALS ± .005 FRACTIONS ± 1/64 ANGLES ± 0°30'
FINAL SURFACE QUALITY REMOVE BURRS AND BREAK SHARP CORNERS

MATERIAL

FINISH

DRN	DATE
<i>W. J. ...</i>	8/7/68
CHK'D	DATE
<i>W. J. ...</i>	12/10/68
ENG	DATE
<i>W. J. ...</i>	11/11/68
PL. OR ENG.	DATE
<i>W. J. ...</i>	11/11/68
PROD.	DATE
<i>W. J. ...</i>	12/11/68
FIRST USED ON	

DEPT. OF DEFENSE
DIGITAL EQUIPMENT CORPORATION
MAYNARD, MASSACHUSETTS

TITLE
DRAWING INDEX LIST

SIZE CODE	NUMBER	REV.
C DI	DW08-0-1	A
DIST.	G	

REV. A
NUMBER DW08-0-1
SIZE CODE C DI

This drawing and specifications, herein, are the property of Digital Equipment Corporation and shall not be reproduced or copied or used in whole or in part as the basis for the manufacture or sale of items without written permission.

SIZE CODE: DW08-B-MU 2

8	7	6	5	4	3	2	1	22	21	20	19	18	17	16	15	14	13	12	11	10	9	8	7	6	5	4	3	2	1						
A										B																									
CABLE		CABLE		CABLE		CABLE		CABLE		CABLE		CABLE		CABLE		CABLE		CABLE		CABLE		CABLE		CABLE		CABLE		CABLE		CABLE		CABLE		CABLE	
AC 08 BUS										AC 09 BUS																									
TO BAC 11										TO BAC 11																									
BIOP 2										BIOP 2																									
BIOP 4										BIOP 4																									
B TS 3										B TS 3																									
B TS 1										B TS 1																									
B INITIA LIZE										B INITIA LIZE																									
BAC 08										BAC 08																									
BAC 09										BAC 09																									
BAC 11										BAC 11																									
BAC 08										BAC 08																									
BAC 09										BAC 09																									
BAC 11										BAC 11																									
BAC 08										BAC 08																									
BAC 09										BAC 09																									
BAC 11										BAC 11																									
BAC 08										BAC 08																									
BAC 09										BAC 09																									
BAC 11										BAC 11																									
BAC 08										BAC 08																									
BAC 09										BAC 09																									
BAC 11										BAC 11																									

REVISIONS	CHK	CHANGE NO	REV
DW08-B-MU			A

DATE: 1/15/68	BY: [Signature]	DATE: 1/15/68	BY: [Signature]
DATE: 1/15/67	BY: [Signature]	DATE: 1/15/67	BY: [Signature]
DATE: 1/13/67	BY: [Signature]	DATE: 1/13/67	BY: [Signature]
DATE: 1/11/67	BY: [Signature]	DATE: 1/11/67	BY: [Signature]
DATE: 1/11/66	BY: [Signature]	DATE: 1/11/66	BY: [Signature]
DATE: 1/11/65	BY: [Signature]	DATE: 1/11/65	BY: [Signature]
DATE: 1/11/64	BY: [Signature]	DATE: 1/11/64	BY: [Signature]
DATE: 1/11/63	BY: [Signature]	DATE: 1/11/63	BY: [Signature]
DATE: 1/11/62	BY: [Signature]	DATE: 1/11/62	BY: [Signature]
DATE: 1/11/61	BY: [Signature]	DATE: 1/11/61	BY: [Signature]
DATE: 1/11/60	BY: [Signature]	DATE: 1/11/60	BY: [Signature]
DATE: 1/11/59	BY: [Signature]	DATE: 1/11/59	BY: [Signature]
DATE: 1/11/58	BY: [Signature]	DATE: 1/11/58	BY: [Signature]
DATE: 1/11/57	BY: [Signature]	DATE: 1/11/57	BY: [Signature]
DATE: 1/11/56	BY: [Signature]	DATE: 1/11/56	BY: [Signature]
DATE: 1/11/55	BY: [Signature]	DATE: 1/11/55	BY: [Signature]
DATE: 1/11/54	BY: [Signature]	DATE: 1/11/54	BY: [Signature]
DATE: 1/11/53	BY: [Signature]	DATE: 1/11/53	BY: [Signature]
DATE: 1/11/52	BY: [Signature]	DATE: 1/11/52	BY: [Signature]
DATE: 1/11/51	BY: [Signature]	DATE: 1/11/51	BY: [Signature]
DATE: 1/11/50	BY: [Signature]	DATE: 1/11/50	BY: [Signature]
DATE: 1/11/49	BY: [Signature]	DATE: 1/11/49	BY: [Signature]
DATE: 1/11/48	BY: [Signature]	DATE: 1/11/48	BY: [Signature]
DATE: 1/11/47	BY: [Signature]	DATE: 1/11/47	BY: [Signature]
DATE: 1/11/46	BY: [Signature]	DATE: 1/11/46	BY: [Signature]
DATE: 1/11/45	BY: [Signature]	DATE: 1/11/45	BY: [Signature]
DATE: 1/11/44	BY: [Signature]	DATE: 1/11/44	BY: [Signature]
DATE: 1/11/43	BY: [Signature]	DATE: 1/11/43	BY: [Signature]
DATE: 1/11/42	BY: [Signature]	DATE: 1/11/42	BY: [Signature]
DATE: 1/11/41	BY: [Signature]	DATE: 1/11/41	BY: [Signature]
DATE: 1/11/40	BY: [Signature]	DATE: 1/11/40	BY: [Signature]
DATE: 1/11/39	BY: [Signature]	DATE: 1/11/39	BY: [Signature]
DATE: 1/11/38	BY: [Signature]	DATE: 1/11/38	BY: [Signature]
DATE: 1/11/37	BY: [Signature]	DATE: 1/11/37	BY: [Signature]
DATE: 1/11/36	BY: [Signature]	DATE: 1/11/36	BY: [Signature]
DATE: 1/11/35	BY: [Signature]	DATE: 1/11/35	BY: [Signature]
DATE: 1/11/34	BY: [Signature]	DATE: 1/11/34	BY: [Signature]
DATE: 1/11/33	BY: [Signature]	DATE: 1/11/33	BY: [Signature]
DATE: 1/11/32	BY: [Signature]	DATE: 1/11/32	BY: [Signature]
DATE: 1/11/31	BY: [Signature]	DATE: 1/11/31	BY: [Signature]
DATE: 1/11/30	BY: [Signature]	DATE: 1/11/30	BY: [Signature]
DATE: 1/11/29	BY: [Signature]	DATE: 1/11/29	BY: [Signature]
DATE: 1/11/28	BY: [Signature]	DATE: 1/11/28	BY: [Signature]
DATE: 1/11/27	BY: [Signature]	DATE: 1/11/27	BY: [Signature]
DATE: 1/11/26	BY: [Signature]	DATE: 1/11/26	BY: [Signature]
DATE: 1/11/25	BY: [Signature]	DATE: 1/11/25	BY: [Signature]
DATE: 1/11/24	BY: [Signature]	DATE: 1/11/24	BY: [Signature]
DATE: 1/11/23	BY: [Signature]	DATE: 1/11/23	BY: [Signature]
DATE: 1/11/22	BY: [Signature]	DATE: 1/11/22	BY: [Signature]
DATE: 1/11/21	BY: [Signature]	DATE: 1/11/21	BY: [Signature]
DATE: 1/11/20	BY: [Signature]	DATE: 1/11/20	BY: [Signature]
DATE: 1/11/19	BY: [Signature]	DATE: 1/11/19	BY: [Signature]
DATE: 1/11/18	BY: [Signature]	DATE: 1/11/18	BY: [Signature]
DATE: 1/11/17	BY: [Signature]	DATE: 1/11/17	BY: [Signature]
DATE: 1/11/16	BY: [Signature]	DATE: 1/11/16	BY: [Signature]
DATE: 1/11/15	BY: [Signature]	DATE: 1/11/15	BY: [Signature]
DATE: 1/11/14	BY: [Signature]	DATE: 1/11/14	BY: [Signature]
DATE: 1/11/13	BY: [Signature]	DATE: 1/11/13	BY: [Signature]
DATE: 1/11/12	BY: [Signature]	DATE: 1/11/12	BY: [Signature]
DATE: 1/11/11	BY: [Signature]	DATE: 1/11/11	BY: [Signature]
DATE: 1/11/10	BY: [Signature]	DATE: 1/11/10	BY: [Signature]
DATE: 1/11/9	BY: [Signature]	DATE: 1/11/9	BY: [Signature]
DATE: 1/11/8	BY: [Signature]	DATE: 1/11/8	BY: [Signature]
DATE: 1/11/7	BY: [Signature]	DATE: 1/11/7	BY: [Signature]
DATE: 1/11/6	BY: [Signature]	DATE: 1/11/6	BY: [Signature]
DATE: 1/11/5	BY: [Signature]	DATE: 1/11/5	BY: [Signature]
DATE: 1/11/4	BY: [Signature]	DATE: 1/11/4	BY: [Signature]
DATE: 1/11/3	BY: [Signature]	DATE: 1/11/3	BY: [Signature]
DATE: 1/11/2	BY: [Signature]	DATE: 1/11/2	BY: [Signature]
DATE: 1/11/1	BY: [Signature]	DATE: 1/11/1	BY: [Signature]

FIRST USED ON OPTION / MODEL PDP-8I	DO NOT SCALE DRAWING UNLESS OTHERWISE SPECIFIED DIMENSION IN INCHES TOLERANCES DECIMALS FRACTIONS ANGLES ± .008 ± .004 ± .003 FIN. SURFACE QUALITY REMOVE BURRS AND BREAK SHARP CORNERS	DATE: 1/15/68 DATE: 1/15/68 DATE: 1/15/67 DATE: 1/13/67 DATE: 1/11/67 DATE: 1/11/66 DATE: 1/11/65 DATE: 1/11/64 DATE: 1/11/63 DATE: 1/11/62 DATE: 1/11/61 DATE: 1/11/60 DATE: 1/11/59 DATE: 1/11/58 DATE: 1/11/57 DATE: 1/11/56 DATE: 1/11/55 DATE: 1/11/54 DATE: 1/11/53 DATE: 1/11/52 DATE: 1/11/51 DATE: 1/11/50 DATE: 1/11/49 DATE: 1/11/48 DATE: 1/11/47 DATE: 1/11/46 DATE: 1/11/45 DATE: 1/11/44 DATE: 1/11/43 DATE: 1/11/42 DATE: 1/11/41 DATE: 1/11/40 DATE: 1/11/39 DATE: 1/11/38 DATE: 1/11/37 DATE: 1/11/36 DATE: 1/11/35 DATE: 1/11/34 DATE: 1/11/33 DATE: 1/11/32 DATE: 1/11/31 DATE: 1/11/30 DATE: 1/11/29 DATE: 1/11/28 DATE: 1/11/27 DATE: 1/11/26 DATE: 1/11/25 DATE: 1/11/24 DATE: 1/11/23 DATE: 1/11/22 DATE: 1/11/21 DATE: 1/11/20 DATE: 1/11/19 DATE: 1/11/18 DATE: 1/11/17 DATE: 1/11/16 DATE: 1/11/15 DATE: 1/11/14 DATE: 1/11/13 DATE: 1/11/12 DATE: 1/11/11 DATE: 1/11/10 DATE: 1/11/9 DATE: 1/11/8 DATE: 1/11/7 DATE: 1/11/6 DATE: 1/11/5 DATE: 1/11/4 DATE: 1/11/3 DATE: 1/11/2 DATE: 1/11/1		EQUIPMENT CORPORATION NATICK, MASSACHUSETTS 01909	
MATERIAL		NEXT HIGHER ASSY	SIZE CODE	NUMBER	REV
FINISH		SCALE	DIMU DW08-B-MU		A

DIGITAL EQUIPMENT CORPORATION

MAYNARD, MASSACHUSETTS

PARTS LIST

MADE BY <i>Robert Gutwale</i>	CHECKED AL PFYFFER	SECTION 1
DATE 8/13/68	DATE 10/7/68	ISSUED SECT. 1
ENG <i>J.P. ...</i>	PROD. <i>S. Vollenweider</i>	DATE 10/16/68

ITEM NO.	DWG NO. / PART NO.	DESCRIPTION	DWG8-B
	M508	BUS CONVERTER	7
	M906	CABLE TERMINATOR	5
	M660	POSITIVE LEVEL DRIVER	2
	M051	LEVEL CONVERTER	4

QUANTITY / VARIATION			
QTY	VARIATION	QTY	VARIATION

TITLE MODULE UTILIZATION	ASSY NO. D-MU-DW08-B-MU	SIZE A	CODE PL	NUMBER DW08-B-MU	REV. A	ECO NO. <i>22068</i> <i>03001</i>
SHEET 1 OF 1		DIST				

This drawing and specifications, herein, are the property of Digital Equipment Corporation and shall not be reproduced or copied or used in whole or in part as the basis for the manufacture or sale of items without written permission.

D

C

B

A

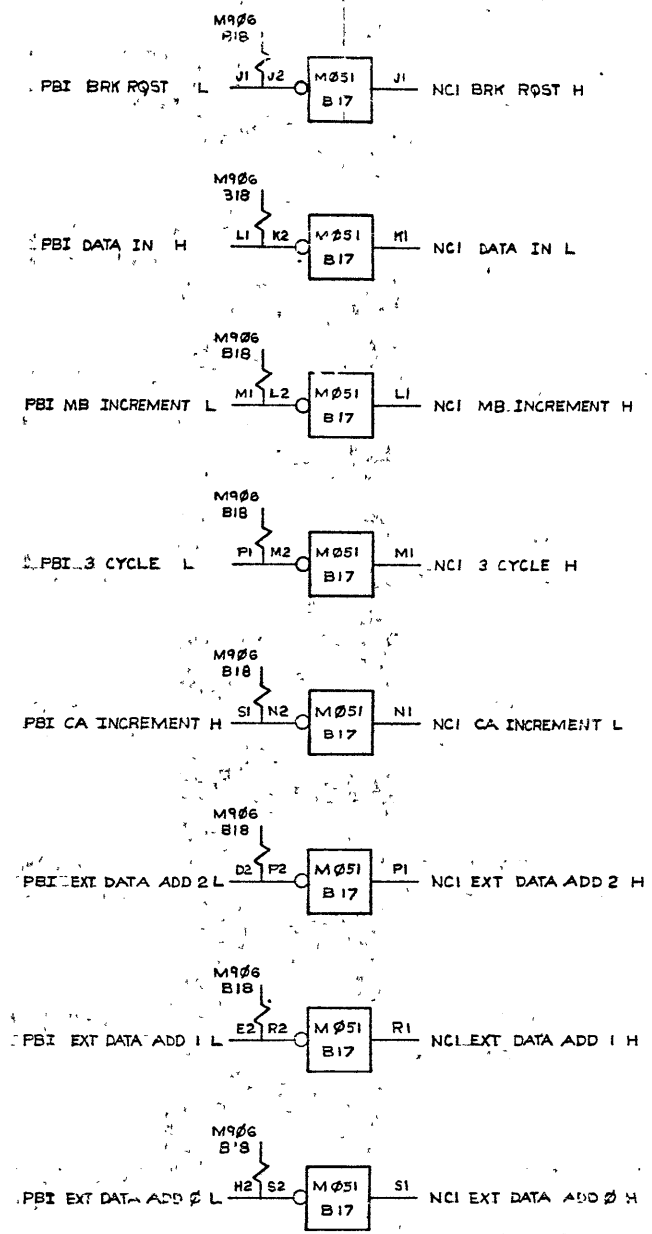
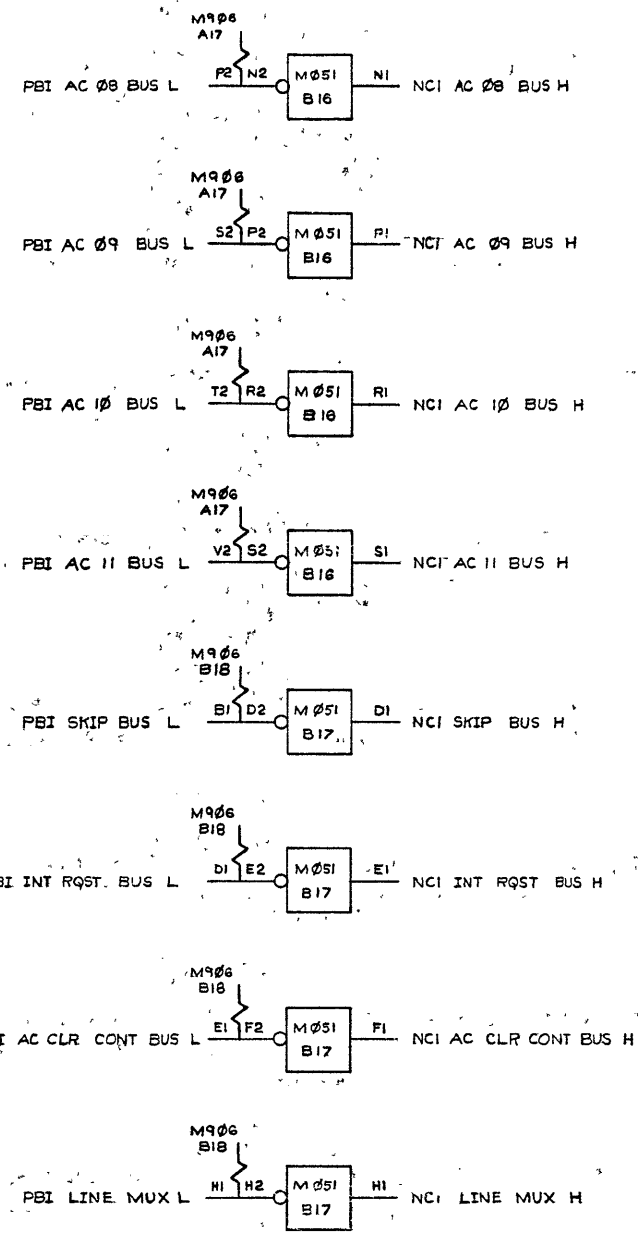
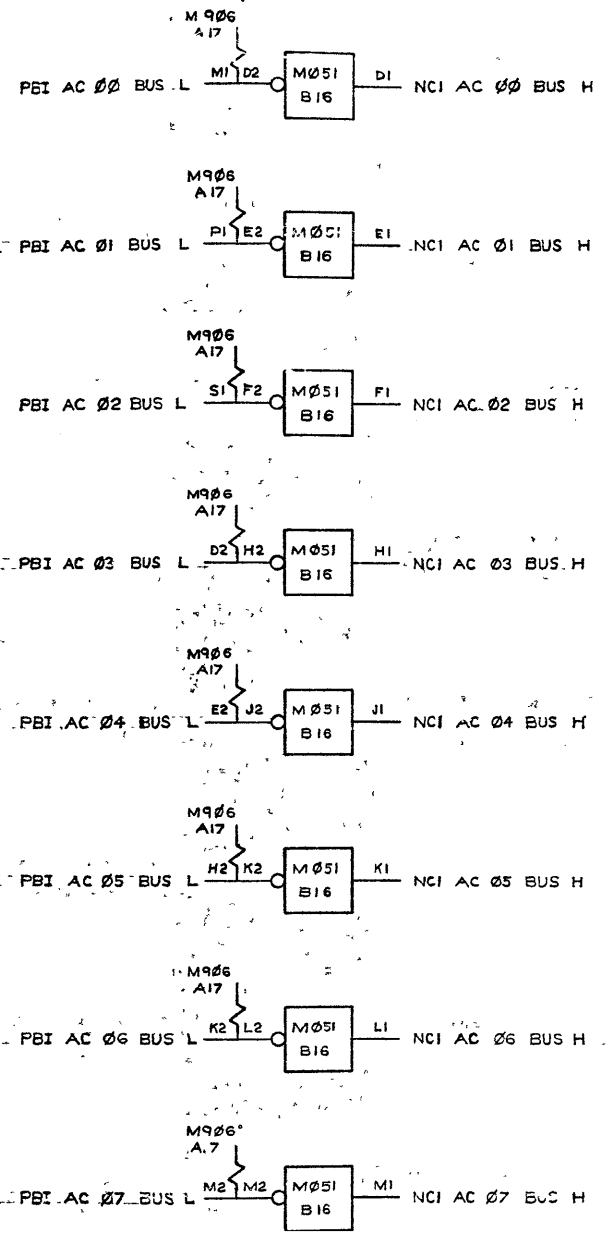

REV	
CHK	
REVISIONS	
CHANGE NO	

FIRST USED ON OPTION/MODEL PDP-8I	QTY	DESCRIPTION	PART NO	ITEM NO
UNLESS OTHERWISE SPECIFIED				
DIMENSION IN INCHES				
TOLERANCES				
DECIMALS	FRACTIONS	ANGLES		
± .005	± 1/64	± 0°30'		
FINISH SURFACE QUALITY				
REMOVE BURRS AND BREAK SHARP CORNERS				
MATERIAL	NEXT HIGHER ASSY			
FINISH	SCALE NONE			
SHEET 1 OF 1				
TITLE NEGATIVE CONVERSION			SIZE CODE DBS	NUMBER DW08-B-NCI
PARTS LIST			DIST	REV

This drawing and specifications, herein are the property of Digital Equipment Corporation and shall not be reproduced or copied or used in whole or in part as the basis for the manufacture or sale of items without written permission.

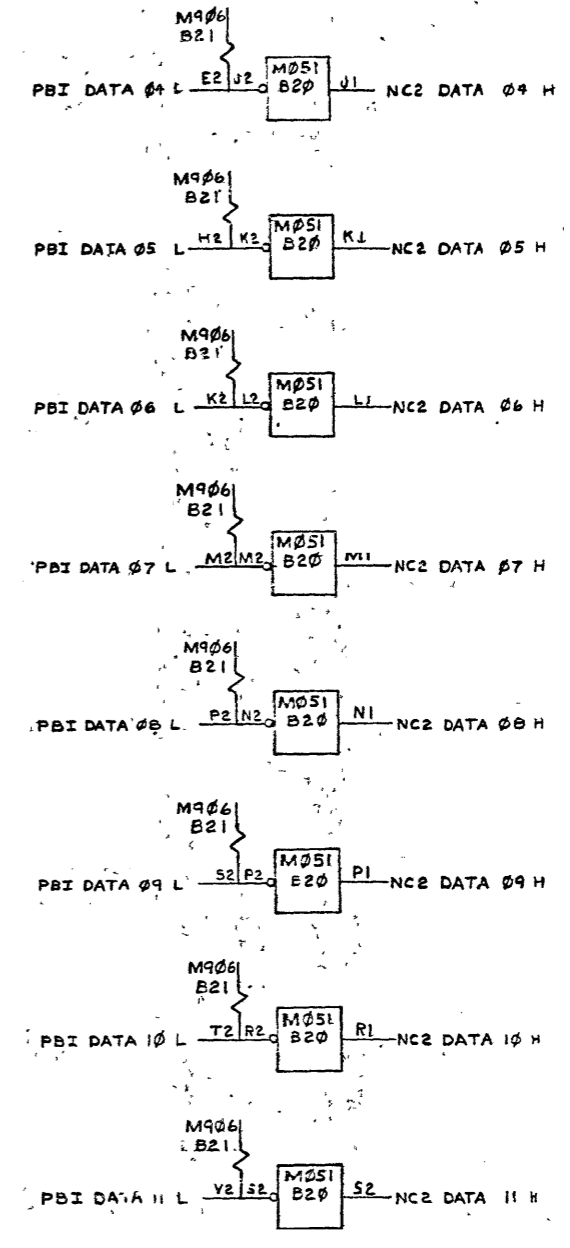
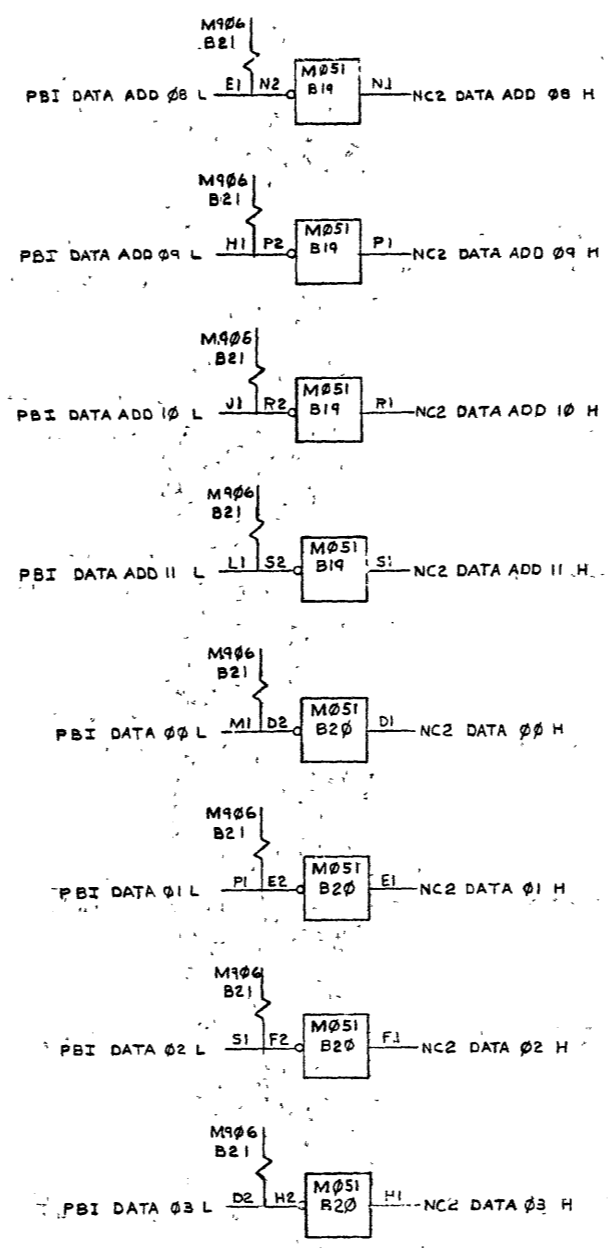
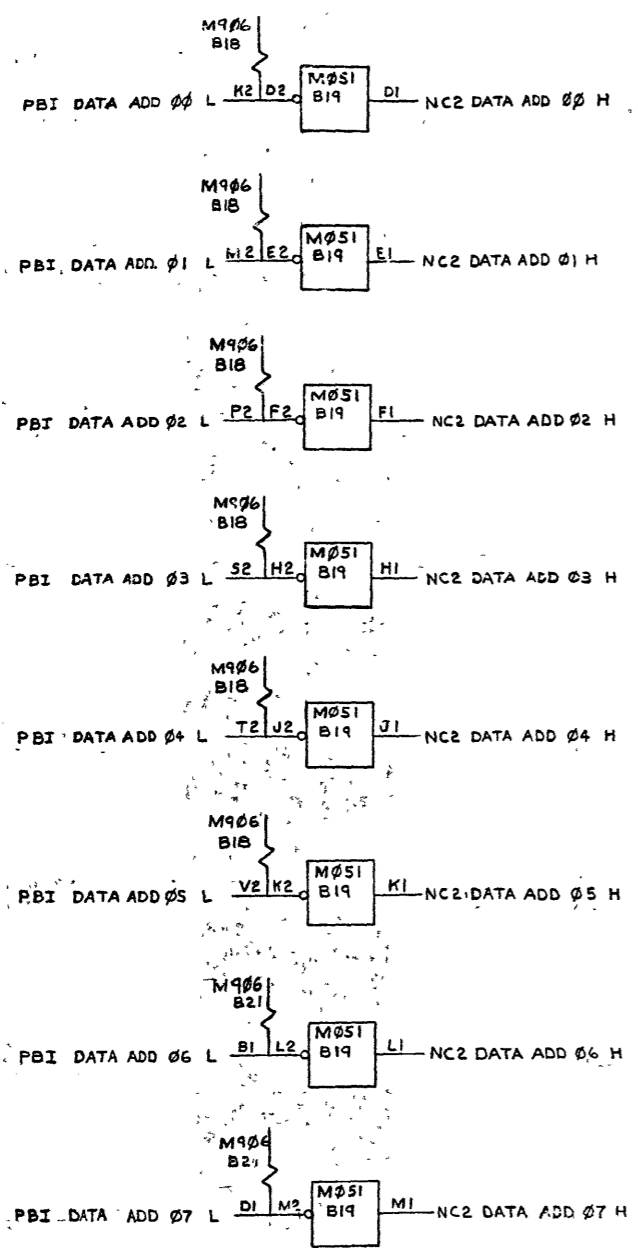

REVISIONS	REV
CHANGE NO	
CHK	

FIRST USED ON OPTON / MODEL	QTY	DESCRIPTION	PART NO	ITEM NO
PDP-8I				
PARTS LIST				
UNLESS OTHERWISE SPECIFIED	DRN	DATE	DIGITAL EQUIPMENT CORPORATION	
UNLESS OTHERWISE SPECIFIED	CHK'D	DATE	MANUFACTURING DIVISION	
DIMENSION IN INCHES	DR	DATE	TITLE	
TOLERANCES	ENG	DATE	NEGATIVE CONVERSION 2	
DECIMALS FRACTIONS ANGLES	PROJ ENG	DATE	SIZE CODE	
± .008 ± 1/64 ± 0°30'	DATE	DATE	NUMBER	
FINAL SURFACE QUALITY	DATE	DATE	DW08-B-NC2	
REMOVE BURRS AND BREAK SHARP CORNERS	DATE	DATE	REV	
MATERIAL	NEXT HIGHER ASSY	DATE	SHEET	
+ + +	A-ML-DW08-B	DATE	OF 1	
FINISH	SCALE NONE	DATE	DIST	
+ + +		DATE		

This drawing and specifications, herein, are the property of Digital Equipment Corporation and shall not be reproduced or copied or used in whole or in part as the basis for the manufacture or sale of items without written permission.

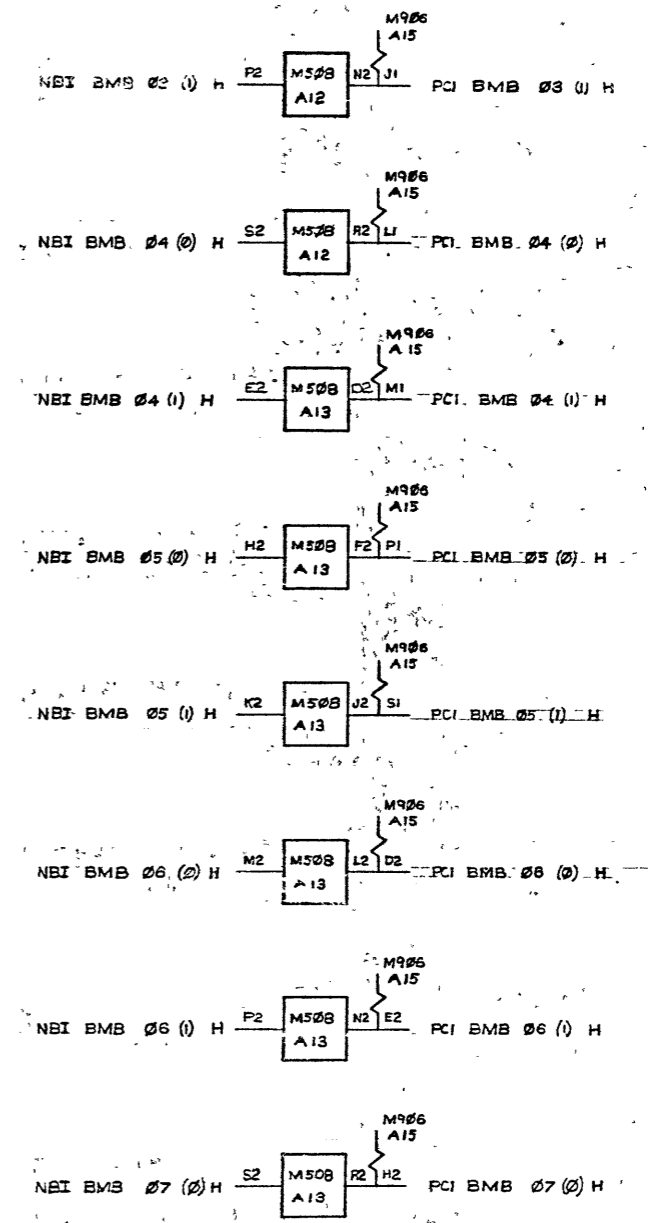
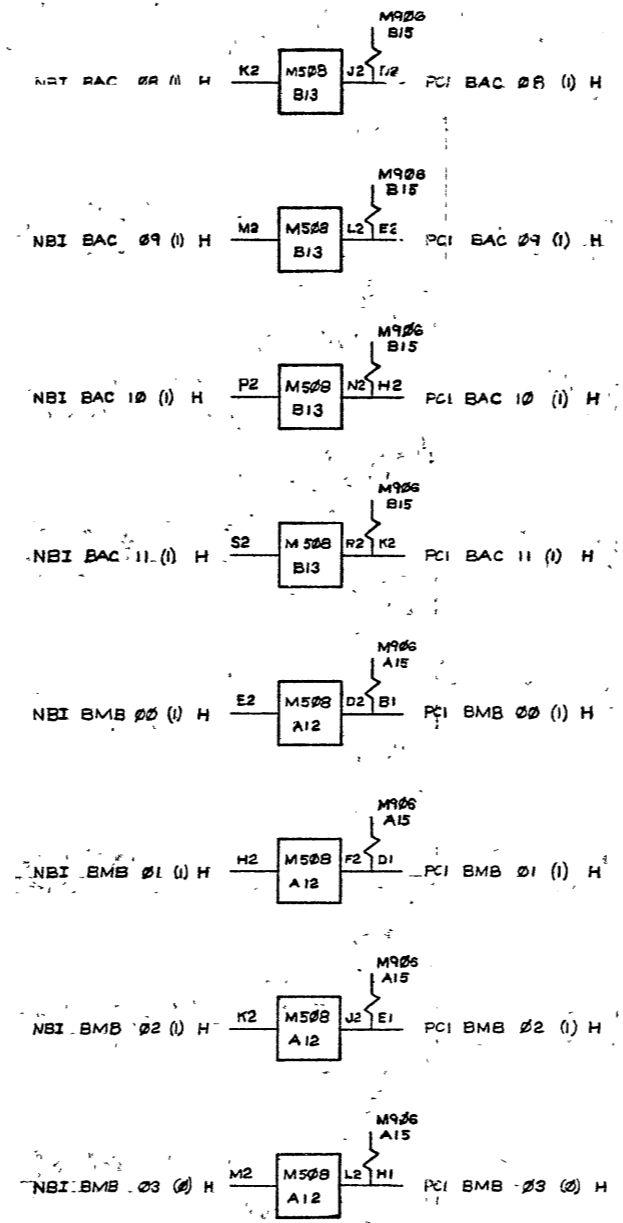
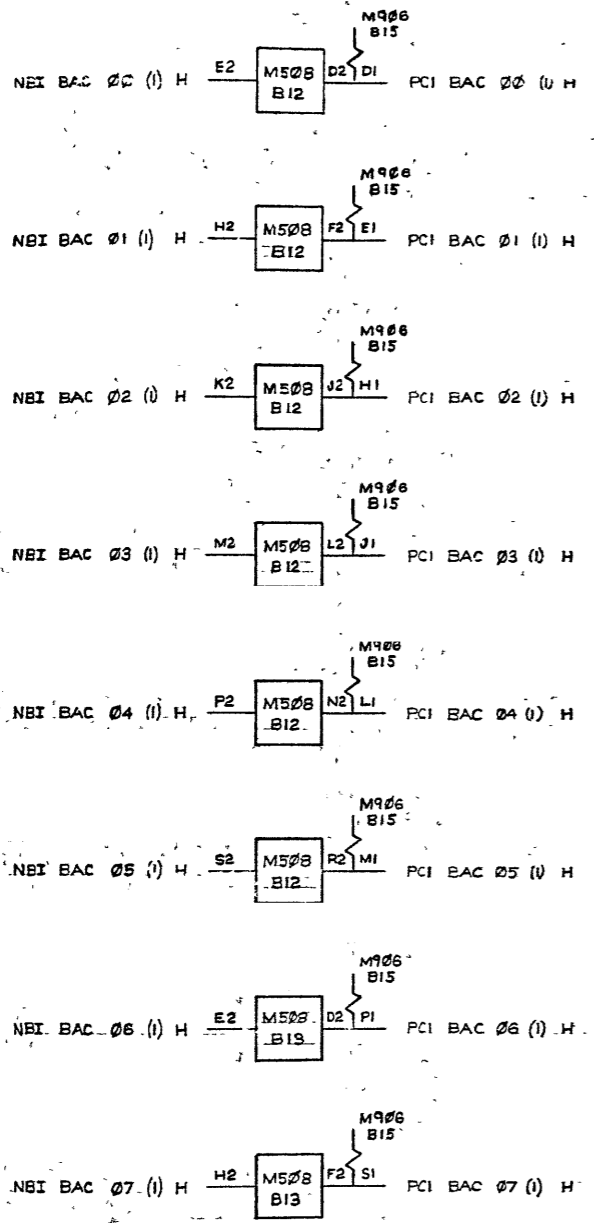

REV	CHG	NO	DATE	BY
1	A	0001	1/13/67	W. J. ...
2	A	0002	1/13/67	W. J. ...
3	A	0003	1/13/67	W. J. ...

FIRST USED ON	COPY	MODEL	QTY	DESCRIPTION	PART NO	ITEM NO
PDP-8I						
UNLESS OTHERWISE SPECIFIED						
DRY	DATE	DATE	DATE	DATE	DATE	DATE
7/1/67	7/1/67	7/1/67	7/1/67	7/1/67	7/1/67	7/1/67
UNLESS OTHERWISE SPECIFIED						
CHK D	DATE	DATE	DATE	DATE	DATE	DATE
1/13/67	1/13/67	1/13/67	1/13/67	1/13/67	1/13/67	1/13/67
TOLERANCES						
DECIMALS	FRACTIONS	ANGLES				
± .005	± 1/64	± 0°30'				
FINAL SURFACE QUALITY						
REMOVE BURRS AND BREAK SHARP CORNERS						
MATERIAL						
NEXT HIGHER ASSY						
A-ML-DW08-B						
FINISH						
SCALE NONE						
SHEET 1 OF 1						

This drawing and specifications, herein, are the property of Digital Equipment Corporation and shall not be reproduced or copied or used in whole or in part as the basis for the manufacture or sale of items without written permission.

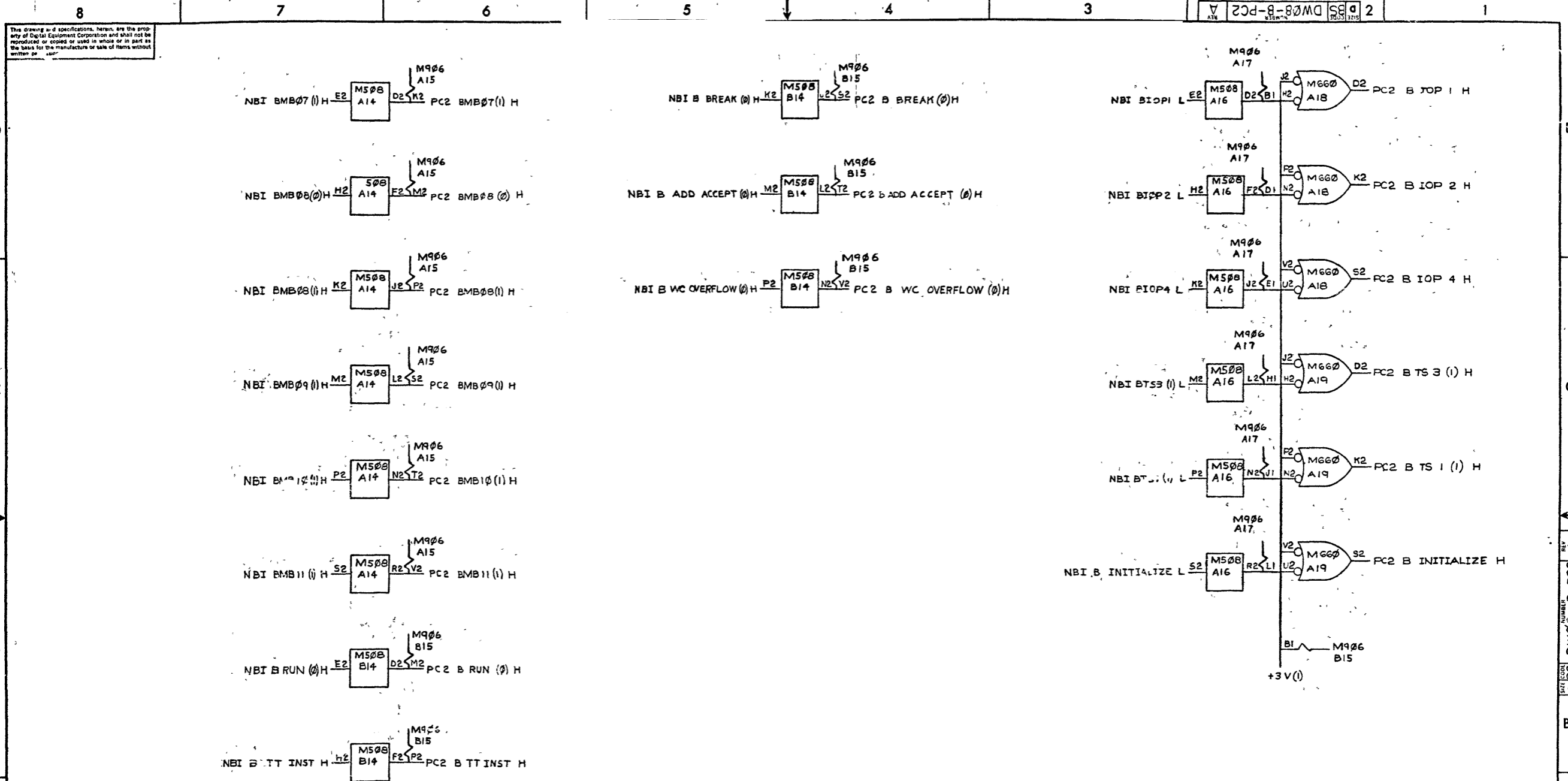

REV	CHG	NO	DATE
1	A	1	3/10/69
2	A	2	3/10/69
3	A	3	3/10/69

DEC FORM NO. DSD-102A

PT. USED ON OPTION / MODEL	QTY	DESCRIPTION	PART NO	ITEM NO
PDP-8I				
UNLESS OTHERWISE SPECIFIED				
DIMENSION IN INCHES		DATE 7-9-68		
TOLERANCES		DATE 2/5/67		
DECIMALS FRACTIONS ANGLES		DATE 10/12/67		
± .005 ± .004 ± .030		DATE 1/2/69		
FINAL SURFACE QUALITY / REMOVE BURRS AND BREAK SHARP CORNERS		DATE 1/2/69		
MATERIAL	NEXT HIGHER ASSY			
FINISH	A-ML-DW08-B			
SCALE NONE	SIZE CODE DBS DW08-B-PC2			
SHEET 1 OF 1	REV 1			

REV A
NUMBER
DBS DW08-B-PC2

This drawing and specifications, herein, are the property of Digital Equipment Corporation and shall not be reproduced or used in whole or in part as the basis for the manufacture or sale of items without written permission.

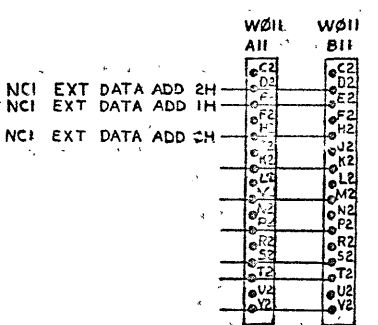
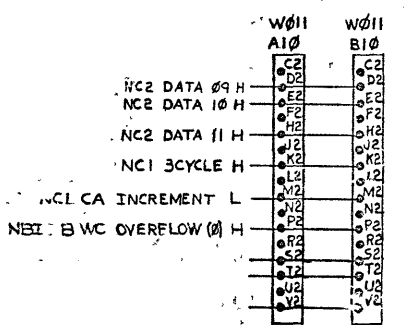
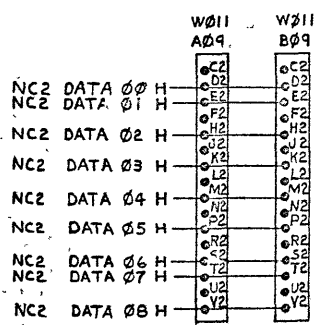
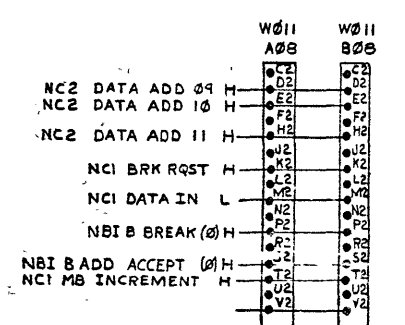
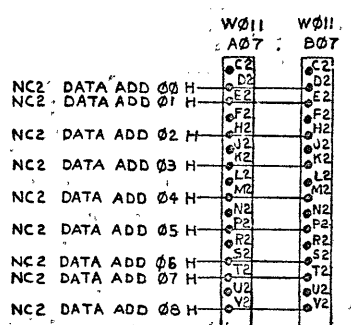
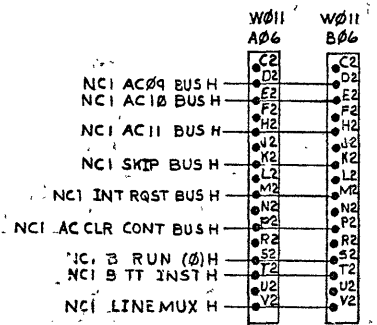
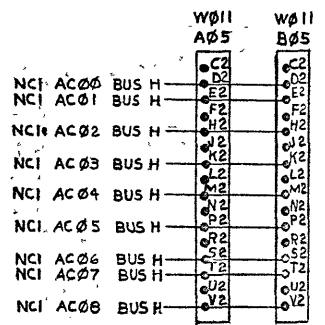
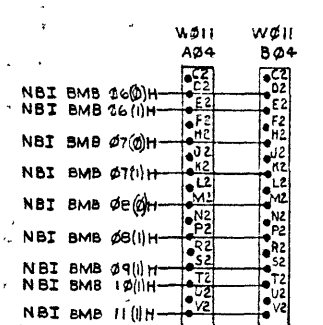
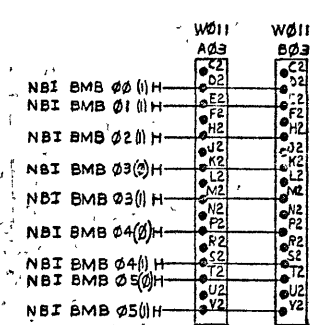
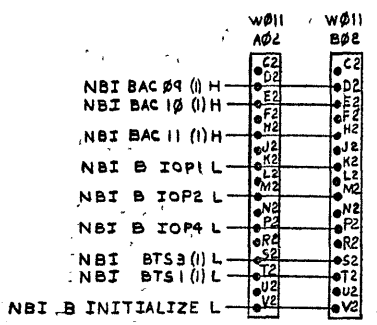
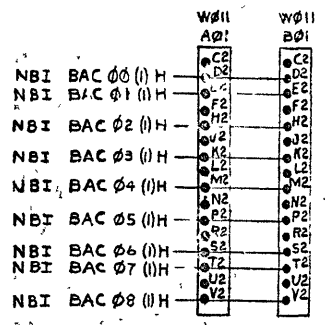

PINS C, E, J, L, N, R & U ARE GROUNDED ON ALL W011'S

REV	CHANGE NO

PREFERRED ON OPTION/MODEL PDP-8I	QTY	DESCRIPTION	PART NO	ITEM NO
UNLESS OTHERWISE SPECIFIED	PARTS LIST			
DIMENSION IN INCHES TOLERANCES: DECIMALS FRACTIONS ANGLES ± .005 ± 1/64 ± 0°30'	DATE 12-1-68 DATE 12-1-68 DATE 12-1-68 DATE 12-1-68 DATE 12-1-68			
FINAL SURFACE QUALITY REMOVE BURRS AND BREAK SHARP CORNERS	DATE 12-1-68 DATE 12-1-68 DATE 12-1-68	TITLE NEGATIVE BUS IN & OUT		
MATERIAL	2-VL-DW08-B	SIZE CODE	DICDW08-B-NBI	REV
FINISH	SCALE NONE	SHEET	OF 1	DIST

This drawing and specifications, herein, are the property of Digital Equipment Corporation and shall not be reproduced or copied or used in whole or in part as the basis for the manufacture or sale of items without written permission.

		M903 A20	
PCI BAC 00 (I) H	AI	BI	
PCI BAC 01 (I) H	CI	DI	
PCI BAC 02 (I) H	EI	FI	
PCI BAC 03 (I) H	HI	J1	
PCI BAC 04 (I) H	K1	L1	
PCI BAC 05 (I) H	M1	N1	
PCI BAC 06 (I) H	P1	R1	
PCI BAC 07 (I) H	S1	T1	
PCI BAC 08 (I) H	C2	D2	
PCI BAC 09 (I) H	E2	F2	
PCI BAC 10 (I) H	H2	J2	
PCI BAC 11 (I) H	K2	L2	
PC2 B IOP 1 H	M2	N2	
PC2 B IOP 2 H	P2	R2	
PC2 B IOP 4 H	S2	T2	
PC2 B TS 3 (I) H	U2	V2	
PC2 B TS 1 (I) H			
PC2 B INITIALIZE H			

		M903 A22	
PBI AC 00 BUS L	AI	BI	
PBI AC 01 BUS L	CI	DI	
PBI AC 02 BUS L	EI	FI	
PBI AC 03 BUS L	HI	J1	
PBI AC 04 BUS L	K1	L1	
PBI AC 05 BUS L	M1	N1	
PBI AC 06 BUS L	P1	R1	
PBI AC 07 BUS L	S1	T1	
PBI AC 08 BUS L	C2	D2	
PBI AC 09 BUS L	E2	F2	
PBI AC 10 BUS L	H2	J2	
PBI AC 11 BUS L	K2	L2	
PBI SKIP BUS L	M2	N2	
PBI INT RQST BUS L	P2	R2	
PBI AC CLR CONT BUS L	S2	T2	
PC2 B RUN (0) H	U2	V2	
PC2 B TT INST H			
PBI LINE MUX L			

		M903 A21	
PCI BMB 00 (I) H	AI	BI	
PCI BMB 01 (I) H	CI	DI	
PCI BMB 02 (I) H	EI	FI	
PCI BMB 03 (0) H	HI	J1	
PCI BMB 03 (I) H	K1	L1	
PCI BMB 04 (0) H	M1	N1	
PCI BMB 04 (I) H	P1	R1	
PCI BMB 05 (0) H	S1	T1	
PCI BMB 05 (I) H	C2	D2	
PCI BMB 06 (0) H	E2	F2	
PCI BMB 06 (I) H	H2	J2	
PCI BMB 07 (0) H	K2	L2	
PCI BMB 07 (I) H	M2	N2	
PCI BMB 08 (0) H	P2	R2	
PCI BMB 08 (I) H	S2	T2	
PCI BMB 09 (I) H	U2	V2	
PCI BMB 10 (I) H			
PCI BMB 11 (I) H			

		M903 A23	
FBI DATA ADD 00 L	AI	BI	
FBI DATA ADD 01 L	CI	DI	
FBI DATA ADD 02 L	EI	FI	
FBI DATA ADD 03 L	HI	J1	
FBI DATA ADD 04 L	K1	L1	
FBI DATA ADD 05 L	M1	N1	
FBI DATA ADD 06 L	P1	R1	
FBI DATA ADD 07 L	S1	T1	
FBI DATA ADD 08 L	C2	D2	
FBI DATA ADD 09 L	E2	F2	
FBI DATA ADD 10 L	H2	J2	
FBI DATA ADD 11 L	K2	L2	
FBI BRK RQST L	M2	N2	
FBI DATA IN H	P2	R2	
PC2 B BREAK (0) H	S2	T2	
PC2 B ADD ACCEPT (0) H	U2	V2	
FBI MB INCREMENT L			
PC2 B INITIALIZE H			

		M903 A24	
FBI DATA 00 L	AI	BI	
FBI DATA 01 L	CI	DI	
FBI DATA 02 L	EI	FI	
FBI DATA 03 L	HI	J1	
FBI DATA 04 L	K1	L1	
FBI DATA 05 L	M1	N1	
FBI DATA 06 L	P1	R1	
FBI DATA 07 L	S1	T1	
FBI DATA 08 L	C2	D2	
FBI DATA 09 L	E2	F2	
FBI DATA 10 L	H2	J2	
FBI DATA 11 L	K2	L2	
FBI 3 CYCLE L	M2	N2	
FBI CA INCREMENT H	P2	R2	
PC2 B WC OVERFLOW (0) H	S2	T2	
FBI EXT DATA ADD 2 L	U2	V2	
FBI EXT DATA ADD 1 L			
FBI EXT DATA ADD 0 L			

PINS AI, CI, FI, KI, NI, RI, TI, C2, F2, J2, L2, N2, R2 & U2 ARE GROUNDED ON ALL M903'S

REV. NO.	REV.
CHANGE NO.	A
CHK	DW08B-C000
DATE	3/11/69
BY	ARSENault
LOC	W 3176

FIRST USED ON OPTION/MODEL PDP-8I	QTY	DESCRIPTION	PART NO	ITEM NO
UNLESS OTHERWISE SPECIFIED				
UNLESS OTHERWISE SPECIFIED	DRY	DATE	PARTS LIST	
DIMENSION IN INCHES	DATE	DATE	DIGITAL EQUIPMENT CORPORATION MILFORD MASSACHUSETTS	
TOLERANCES	DATE	DATE	TITLE	
DECIMALS ± .02	DATE	DATE	POSITIVE BUS	
FRACTIONS ± 1/64	DATE	DATE	IN & OUT	
ANGLES ± 0°30'	DATE	DATE	SIZE CODE NUMBER REV	
FINAL SURFACE QUALITY	DATE	DATE	D I C D W 0 8 - B - P S A	
REMOVE BURRS AND BREAK SHARP CORNERS	DATE	DATE	SCALE NONE	
MATERIAL	DATE	DATE	SHEET 1 OF 1	
+	DATE	DATE	DIST	
+	DATE	DATE		

REV. A
D I C D W 0 8 - B - P S

This drawing and specifications remain the property of Digital Equipment Corporation and shall not be reproduced or copied or used in whole or in part as the basis for the manufacture or sale of items without written permission.

NOTES:

1. CONNECTIONS ON ITEMS *1 & *2 TO BE SOLDERED AND LOCATED AT MINIMUM PRACTICAL HEIGHT ABOVE BOARD.
2. ALL CONN BLOCKS TO BE GROUNDED TO GND LUGS AS SHOWN.
3. USE YELLOW WIRE (ITEM *3) FOR MACHINE WRAPPED & BLUE WIRE (ITEM *4) FOR HAND WRAPPED WIRING.

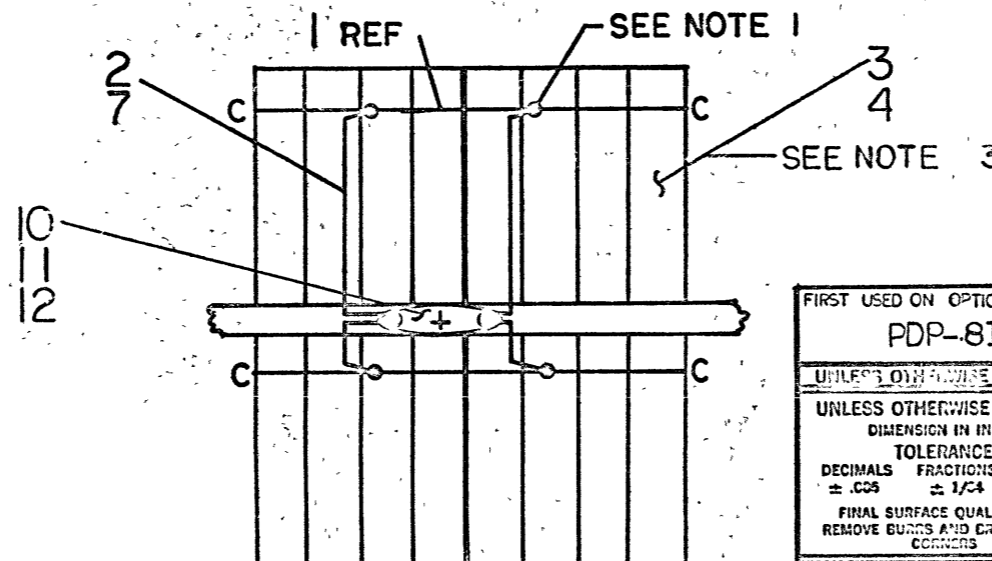
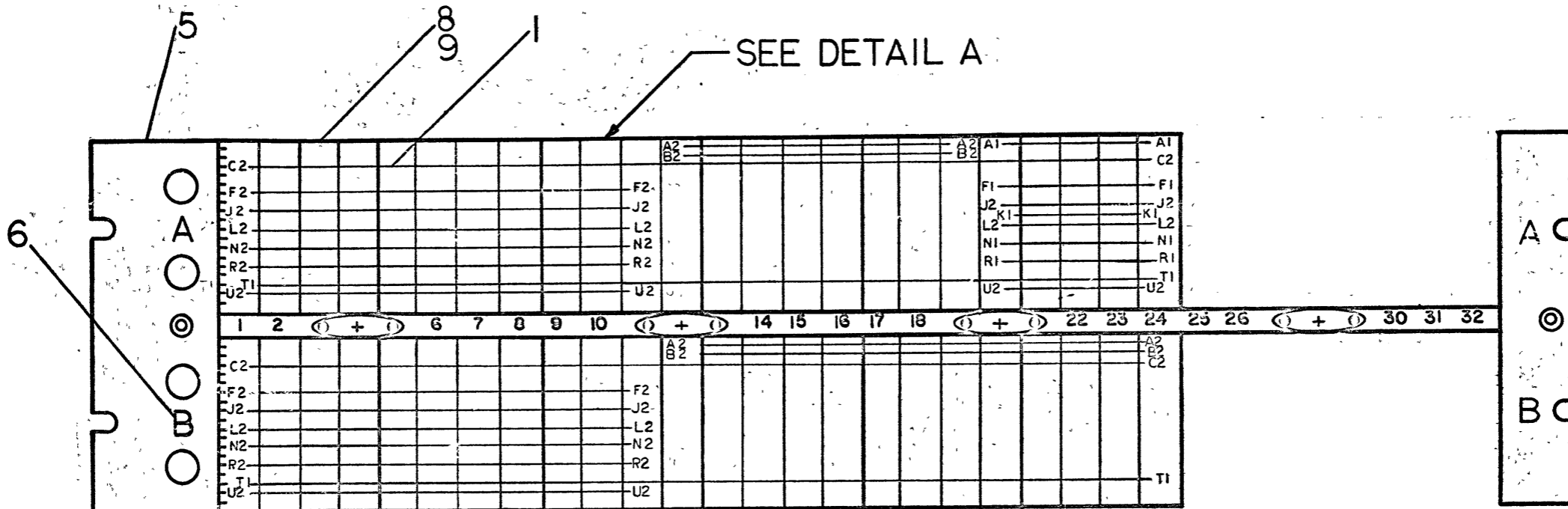

DETAIL A
PLACES
SEE NOTE 2

FIRST USED ON OPTION / MODEL	QTY.	DESCRIPTION	PART NO.	ITEM NO.
PDP-8I				
PARTS LIST				
UNLESS OTHERWISE SPECIFIED		DATE 8/13/68	 EQUIPMENT CORPORATION MAYNARD MASSACHUSETTS	
UNLESS OTHERWISE SPECIFIED		DATE 10-20-68		
DIMENSION IN INCHES		DATE 10/13/68	TITLE WIRED ASSY DWØ8-B	
TOLERANCES		DATE 10-16-68		
DECIMALS FRACTIONS ANGLES			SIZE CODE NUMBER REV. CAD 7005934-0-0	
± .005 ± 1/64 ± 0°30'			DIST	
FINAL SURFACE QUALITY REMOVE BURRS AND BREAK SHARP CORNERS				
MATERIAL	NEXT HIGHER ASSY			
FINISH	A-ML-DWØ8-B			
	SCALE NONE			
	SHEET 1 OF 1			

REV.	CHANGE NO.	CHK

NUMBER
 CAD 7005934-0-0
 REV.

DIGITAL EQUIPMENT CORPORATION MAYNARD, MASSACHUSETTS

PARTS LIST

QUANTITY/VARIATION

MADE BY	R. HUTNACK	CHECKED	AL PFYFFER	SECTION
DATE	8/9/68	DATE	9/25/68	1
ENG	<i>[Signature]</i>	PROD	<i>B. Vallancourt</i>	ISSUED SEC ^t .
DATE	10/13/68	DATE	10/14/68	1

ITEM NO	DWG NO. / PART NO.	DESCRIPTION
1	12-05541	BUS STRIP
2	91-07560-1	#22 AWG WIRE BUS
3	91-05740-5	#30 AWG SOLID INS WIRE YEL
4	91-05740-7	#30 AWG SOLID INS WIRE BLU
5	D-AD-5302483-0-0	1943 CASTING PLUS PINS
6	A-DC-7406371-0-0	LOGIC FRAME DECALS
7	91-07265	TUBING, TEFLON #22 WHITE
8	12-05348	399 PIN CONN BLOCK TYPE H803
9	90-06039-1	SCR PHL HD FIL #8-32x 1/2 LG SST
10	90-07597	TERMINAL #2116-08-00 SHAKEPROOF
11	90-06035-1	SCR PHL HD FIL #8-32x1/4 LG SST
12	90-06634	WASH INT TOOTH #8

DW08-B																			

TITLE	ASSY NO.	SIZE	CODE	NUMBER	REV	ECO NO.
WIRED ASSY DW08-B	C-AD-7005934-0-0	A	PL	7005934-0-0		
	SHEET 1 OF 1	DIST	Ⓞ			

DRWG NO

K-WL-DWØ8-B-WL

REVLTR

B

REVISIONS			
REV LTR	ECO NO	DATE	ENG
A	DWØ8-B 00001	3/11/68	WJA
B	DWØ8-B 00002	2-17-10	WJA

DRAWN <i>Robert H. H. H.</i>	DATE 9/30/68	 EQUIPMENT CORPORATION MAYNARD, MASSACHUSETTS	TITLE WIRE LIST DWØ8-B				
CHECKED <i>A. J. J.</i>	DATE 10-10-68		FOR TAPE # FILE #				
ENG <i>W. J. J.</i>	DATE 10/13/68		ASSY NO C-UA-DWØ8-Ø-Ø	SIZE K	CODE WL	DWG NO. DWØ8-B-WL	REV LTR B
PROJ ENG <i>W. J. J.</i>	DATE 10/13/68		SCALE NONE	SHEET 1	OF 1	DIST.	
PROD <i>B. J. J.</i>	DATE 10/14/68						

DIGITAL EQUIPMENT CORPORATION

MAYNARD, MASSACHUSETTS

ACCESSORY LIST

LEGEND

- D DOCUMENT
- DN DOCUMENT CHANGE NOTICE
- PA PAPER TAPE ASCII
- PB PAPER TAPE BINARY
- PM PAPER TAPE READ-IN-MODE

QUANTITY/VARIATION

MADE BY DATE <i>Dee Moran</i>		CHECKED DATE <i>3/13/70</i>	SECTION
ENG DATE <i>3/12/70</i>		PROD DATE <i>3/13/70</i>	ISSUED SECT.

ITEM NO.	DWG NO. / PART NO.	DESCRIPTION	QUANTITY	KIT CHECK	BY	DATE	INSTALLATION CHECK	BY	DATE
1.	DEC-70-5820-3	I/O Cables 6'	11						
2.	91-07673	A/C Cables	1						
3.	90-08851	Mounting Hardware	1						
4.	DW08B-0-0	Prints	1						
		No Software with this Option							

TITLE Negative to Positive I/O Bus Conversion	ASSY. NO. 	SIZE A	CODE A	NUMBER DW08-B-3	REV. 	ECO NO
SHEET OF	DIST.					

DIGITAL EQUIPMENT CORPORATION
MAYNARD, MASSACHUSETTS

ENGINEERING SPECIFICATION

DATE 9/17/68

TITLE DW08B NEGATIVE TO POSITIVE BUS CONVERTER

REVISIONS

REV	DESCRIPTION	CHG NO	ORIG	DATE	APPD BY	DATE

ENG <i>J. F. Dougherty</i>	APPD <i>J. F. Dougherty</i>	SIZE A	CODE SP	NUMBER DW08-B-2	REV
DEC FORM NO. DRA 107		SHEET 1 OF 5			

This drawing and specifications, herein, are the property of Digital Equipment Corporation and shall not be reproduced, copied or used in whole or in part as the basis for, the manufacture or sale of items without written permission.

ENGINEERING SPECIFICATION

CONTINUATION SHEET

TITLE DW08A NEGATIVE TO POSITIVE BUS CONVERTER

connectors at locations A20 to A24.

Input signals within the Positive Bus are clamped by the M906 modules and level shifted in four M050 modules. This combination converts a low level in (0 volts) to a high level out (0 volts), and a high level in (+3 volts) to a low level out (-3 volts); both the Negative and Positive buses' input signals are active when clamped to ground (0 volts).

Delays occur within the DW08A unit and affect both the input and output signals within the Buses. A maximum propagation delay of 100 nanoseconds exists in output timing signals (BIOP1, BIOP2, BIOP4, BTS3(1), BTS1(1) and INITIALIZE); a maximum propagation delay of 50 nanoseconds exists for the other output signals.

The input signal propagation delay through the M051 is maximum at 60 nanoseconds. The round trip propagation delay (160 nanoseconds) of the timing signal reduces the cable length allowed between the computer and peripheral. At a rate of 3 microseconds per round trip foot, the cable length reduction for 160 nanoseconds delay is approximately 50 feet. A maximum of 20 feet of cable is allowed, with the maximum of 14 feet for flexprint still applicable. The half transitions of unterminated signals exists upon both Buses with their duration dependent upon cable lengths and placement of the DW08B upon the Negative Bus.

SIZE A	CODE SP	NUMBER DW08-B-2	REV
DEC FORM NO. DRA 108		SHEET 3 OF 5	

ENGINEERING SPECIFICATION

CONTINUATION SHEET

TITLE DW08B NEGATIVE TO POSITIVE BUS CONVERTER

0.0 **HARDWARE SPECIFICATIONS**

0.1 Overall Description

A bus conversion unit that accepts a Negative Bus and outputs a Positive Bus and a continuation of the Negative Bus. (The name Bus denotes a combination of input (received by the computer) and output (sent by the computer) signals.) The unit is contained upon a single mounting panel with 48 module locations and an integral power supply.

1.0 **GENERAL SPECIFICATIONS**

1.1 Basic System

Level converters and diode clamps are provided for both positive and negative level signals. The Negative Bus (with LEC levels of 0 volts and -3 volts) inputs on eleven W011 or W031 cable connectors at locations A01 to A11. The Negative Bus outputs on eleven W011 or W031 cable connectors at location B01 to B11. The output signals from the Negative Bus are connected to the diode, clamps and difference amplifiers of the M508 modules with additional resistor clamps of the M906 modules on the output. These modules produce a 0 volt signals on the Positive Bus for a 0 volt on the Negative Bus. Certain timing signals (BIOP1, BIOP2, BIOP4, BTS3(1), BTS1(1) and B INITIALIZE) are inverted in two M660 modules capable of driving terminated cables. The Positive Bus outputs on five M903 or M904 cable

SIZE A	CODE SP	NUMBER DW08-B-2	REV
DEC FORM NO. DRA 108		SHEET 2 OF 5	

ENGINEERING SPECIFICATION

CONTINUATION SHEET

TITLE DW08E NEGATIVE TO POSITIVE BUS CONVERTER

1.2 Options usual to the PDP8/I Positive Bus are accommodated by this conversion unit on the Negative Bus.

1.3 The option is mounted upon a single mounting panel with 48 connector (6 connector blocks) and an integral power supply. The panel can be mounted in standard 19 inch racks. A cabinet depth of 15 inches is required for the power supply.

1.4 The environmental specifications are those of the PDP8/I. The DC logic voltage of +5 volts (at 2.6 amperes) and -15 volts (at 0.5 amperes) are provided by the integral power supply noted.

1.5 General Performance Specifications

DW08B accepts and outputs a Negative Bus similar to that of the PDP8. These signals are converted to a Positive Bus compatible to that produced by the KA8I but having a reduced total cable length of 20 feet. The cable length on both the Positive and Negative Buses must be included. (The restriction of flexprint to 14 feet is still applicable.)

2.0 **SPECIFICATION OF VENDOR-SUPPLIED EQUIPMENT**

The integral power supply is from Wanlass Electric Company, Model C-148.

AC Inputs: 120 or 240 V AC +10%, 50 to 60 HZ, single phase.

SIZE A	CODE SP	NUMBER DW08-B-2	REV
DEC FORM NO. DRA 108		SHEET 4 OF 5	